

64-2600 Series

Regulators - Pressure Reducing

D64261732X012

Specifications

For other materials or modifications, please consult TESCOM.

OPERATING PARAMETERS

Pressure rating per criteria of ANSI/ASME B31.3

Maximum Inlet Pressure

600 or 3500 psig / 41.4 or 241 bar

Outlet Pressure Ranges

0-30, 0-60, 0-100, 0-150 and 250 psig
0-2.1, 0-4.1, 0-6.9, 0-10.3 and 17.2 bar

Design Proof Pressure

150% of maximum rated

Inboard Leak Rate

1×10^{-9} atm cc/sec He

Operating Temperature

PTCFE Seat: -40°F to 140°F / -40°C to 60°C

Teflon® Seat: -40°F to 160°F / -40°C to 71°C

VespeI® Seat: -40°F to 350°F / -40°C to 177°C

Flow Capacity

$C_v = 0.06$ (3500 psig / 241 bar model)

$C_v = 0.15$ (600 psig / 41.4 bar model)

Decaying Inlet Characteristic

$C_v = 0.06$: 0.7 per 100 psig / 0.05 per 6.9 bar



TESCOM 64-2600 Series economical high purity pressure reducing regulator provides Stainless Steel construction with 10 R_a surface finish and is electronic grade cleaned. Inlet pressures are 600 or 3500 psig / 41.4 or 241 bar with outlet pressures of up to 250 psig / 17.2 bar.

MEDIA CONTACT MATERIALS

Body

316L Stainless Steel Electropolish or
316L VAR Stainless Steel Electropolish

Diaphragm

316L Stainless Steel or Hastelloy®

Seat

PCTFE or Teflon® (VespeI® optional for 3500 psig / 241 bar model only)

Spring

316 Stainless Steel or Elgiloy®

Stem, Seat Retainer, Valve Guide

316 Stainless Steel or Hastelloy®

OTHER

Internal Surface Finish

10 R_a microinch / 0.25 micrometer

Connections

Welded female or male VCR®

Tube stubs

High Purity Internal Connections (H.P.I.C.)

(Internal style of VCR®, compatible with male swivel VCR®)

Cleaning

DI water electronic grade cleaned and ES 500 Particle Certified for internal electropolish models

Internal Volume

1/4" fitting / 5.75 cc

Weight (without gauges)

2 lbs / 0.9 kg

Teflon® and VespeI® are registered trademarks of E.I. du Pont de Nemours and Company.

Hastelloy® is a registered trademark of Haynes International, Inc.

Elgiloy® is a registered trademark of Elgiloy Corp.

VCR® is a registered trademark of Cajon Co.

*Material to be Hastelloy® or equivalent per ASTM B 574

Applications

- 1/4" point-of-use
- Gas cabinets
- Semiconductor manufacturing
- Valve manifold boxes
- Research labs

Features and Benefits

- Optimum performance and cleanliness at a great value
- Internal surface finished to 10 R_a microinch / 0.25 micrometer ensures minimal particle generation or entrapment
- True metal-to-metal body diaphragm seal provides enhanced leak integrity
- No bias spring or friction device in the flow stream
- Adjustable stop to limit outlet pressure
- Positionable ported bonnet ring is available

64-2600 Series Regulator Drawing

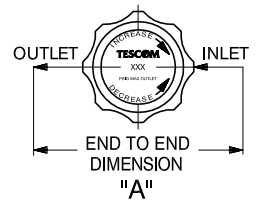
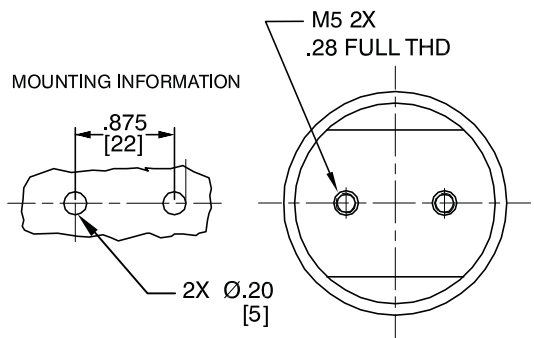
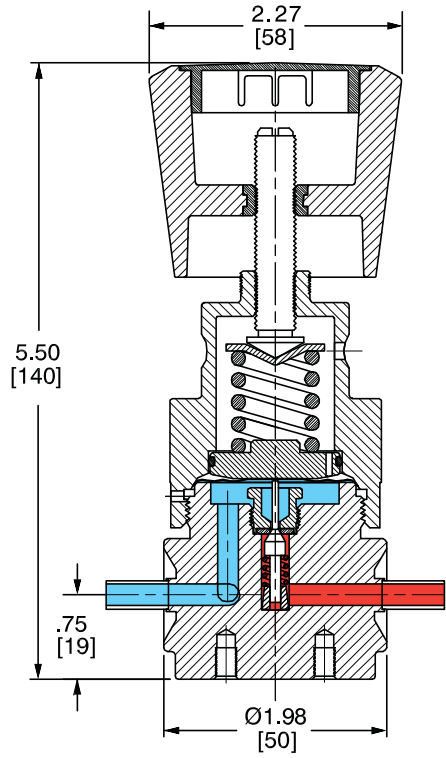

**Figure A
(no gauges)**

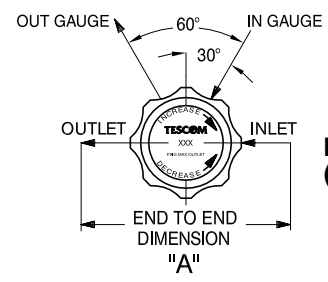

**Figure B
(2 gauges)**

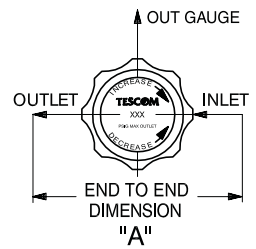

**Figure C
(1 gauge)**

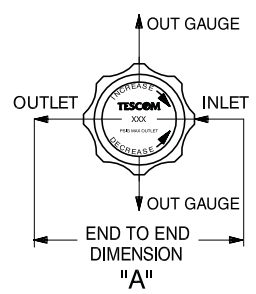
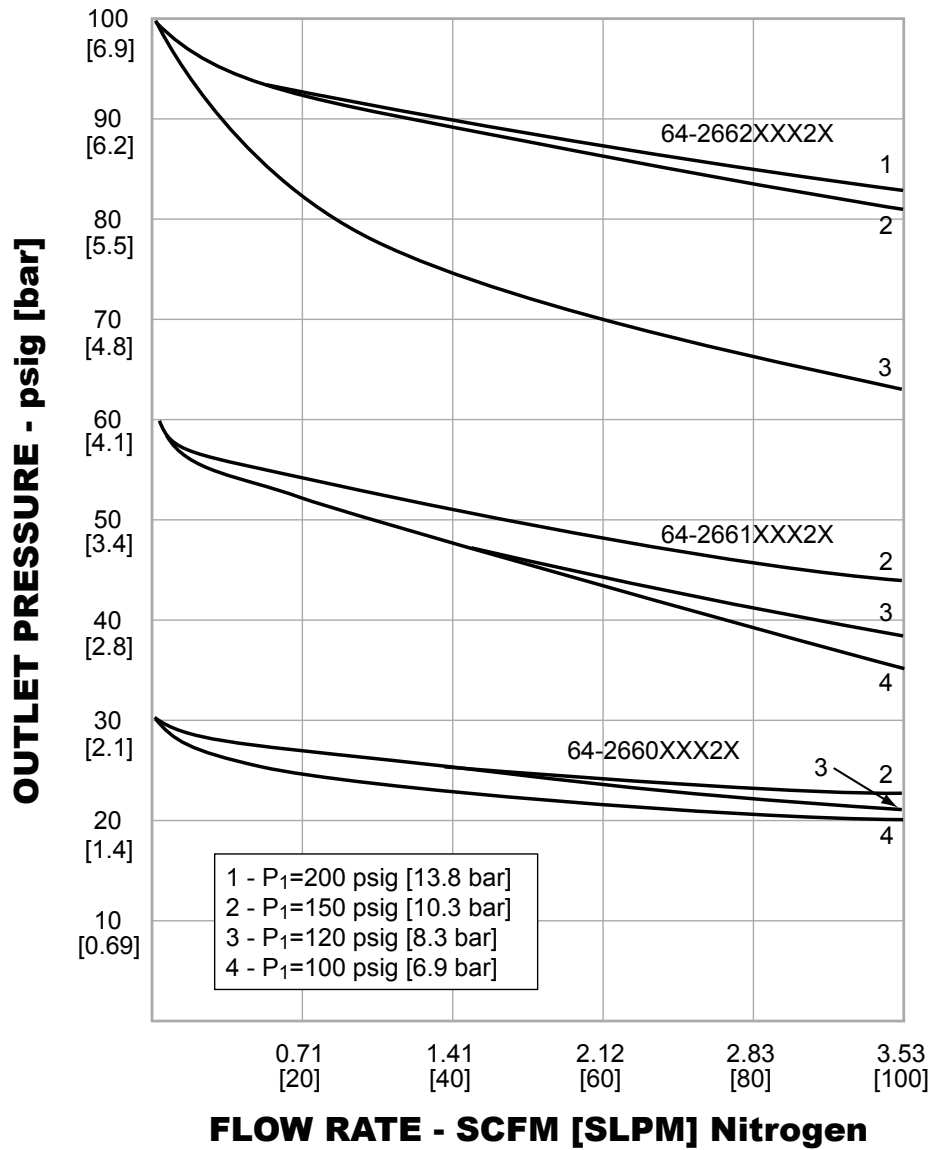

**Figure D
(2 out gauges)**

All dimensions are reference & nominal
Metric [millimeter] equivalents are in brackets

64-2600 Series Regulator Flow Chart

For more information on how to read flow curves, please refer to the Flow Curves and Calculations document (debul2007x012) in the TESCOM catalog or on www.tescom.com.



64-2600 Series Regulator Part Number Selector

Repair Kits, Accessories & Modifications may be available for this product. Please contact TESCOM for more information.

Example for selecting a part number:

64-26	4	2	K	A4		1	0	
BASIC SERIES	BODY MATERIAL/ FINISH	OUTLET PRESSURE RANGES	SEAT MATERIAL	INLET AND OUTLET PORT SIZE AND TYPE	'A' ± .06"	MAXIMUM INLET	GAUGE PORT OPTION	NO. OF GAUGE PORTS (SEE FIGURE)
64-26	4 – 316L Stainless Steel Electropolish: 10 R _a ¹	0 – 0-30 psig 0-2.1 bar	K – PCTFE	A4 – 1/4" H.P.I.C.	-	1 – 3500 psig 241 bar	0 – None	0 (Figure A)
	6 – 316L VAR Stainless Steel Electropolish: 10 R _a ²	1 – 0-60 psig 0-4.1 bar	T – Teflon®	RK – 1/2" Male Swivel	4.75"	316 Stainless Steel Trim	1 – 1/4" H.P.I.C.	1 (Figure C)
		2 – 0-100 psig 0-6.9 bar	V – Vespel® (3500 psig / 241 bar model only)	RL – 1/2" Female Swivel	4.75"	2 – 600 psig 41.4 bar	2 – 1/4" H.P.I.C.	2 (Figure B)
		3 – 0-250 psig 0-17.2 bar		RM – 1/4" Male Swivel	3.70"	316 Stainless Steel Trim	3 – 1/4" H.P.I.C.	2 (Figure D)
		6 – 0-150 psig 0-10.3 bar		RT – 1/4" Female Swivel	3.70"	2 – 600 psig 41.4 bar	4 – 1/4" Male Swivel	2 (Figure D)
				RU – IN Port: 1/4" Male; OUT Port: 1/4" Female	3.70"	316 Stainless Steel Trim	5 – 1/4" Male Swivel	1 (Figure C)
				RV – IN Port: 1/4" Female; OUT Port: 1/4" Male	3.70"	3 – 3500 psig 241 bar	6 – 1/4" Male Swivel	2 (Figure B)
				T4 – 1/4" Tube Stubs	3.00"	Hastelloy® Trim	7 – 1/4" Female Swivel	2 (Figure D)
						4 – 600 psig 41.4 bar	8 – 1/4" Female Swivel	1 (Figure C)
						Hastelloy® Trim	9 – 1/4" Female Swivel	2 (Figure B)
							S – 1/4" Fixed Male	2 (Figure B)
							T – 1/4" Fixed Male	1 (Figure C)
							U – 1/4" Fixed Male	2 (Figure D)

1. Per ASTM B 912
2. Per SEMI F19, HP grade